

OF

ALIPLAST OFFICE



The chamber system without thermal insulation intended for designing interior partition walls.

OFFICE

The chamber system without thermal insulation intended for designing interior partition walls.

Various infill options: glass, drywall, laminated furniture board.

Possible infill thickness:

- glass: from 4 mm to 13,8 mm
- laminated furniture board: 18 mm
- drywall: 12,5 mm.

The design of the system provides space for routing electrical cables and installing all kinds of switches, sockets and circuit breakers.

Aliplast Office features very good sound insulating parameters: R_w up to 42 dB.

Possible options:

- Econoline system doors: both single and double doors using a dedicated profile
- fully-glazed doors with door hardware made by renowned manufacturers
- wooden non-rebated doors with hidden hinges.

The design of the system provides for the possibility of using blinds integrated between the glass panes.

Aliplast Office combines functional and aesthetic values, it is a perfect solution if you need to divide large office spaces.

The system's prefabrication is very simple and quick because time-consuming and expensive processing is reduced to a minimum.

A wide range of colours available: RAL palette (Qualicoat 1518), Aliplast Wood Colour Effect (Qualideco PL-0001), anodized finish (Qualanod – 1808), bi-colour.

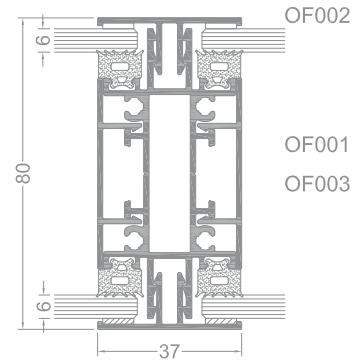

ALIPLAST OFFICE

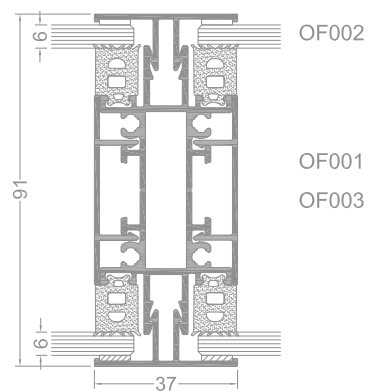

ALIPLAST OFFICE

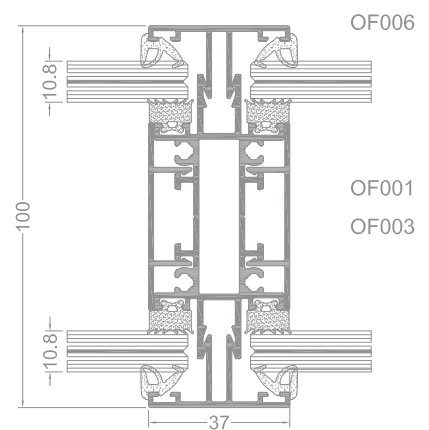

ALIPLAST OFFICE

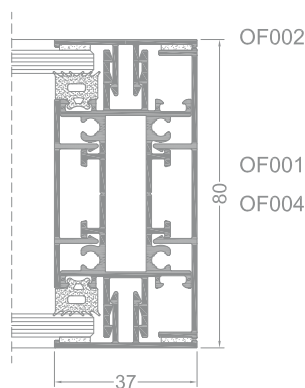

ALIPLAST OFFICE

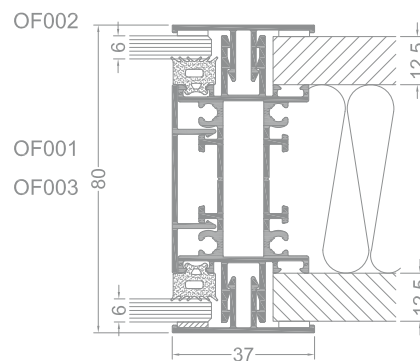

ALIPLAST OFFICE